

# 1/2 L4TR STRADEASY®

À radier à reconstituer



C 250



P 98-050-1



Masque pré-cassable

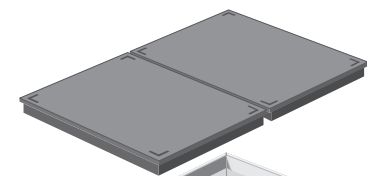

2 tampons\*  
633 x 495 mm

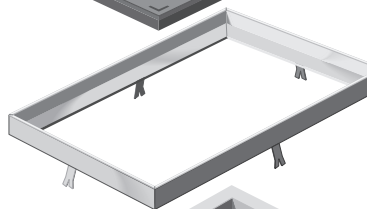

Cadre\*

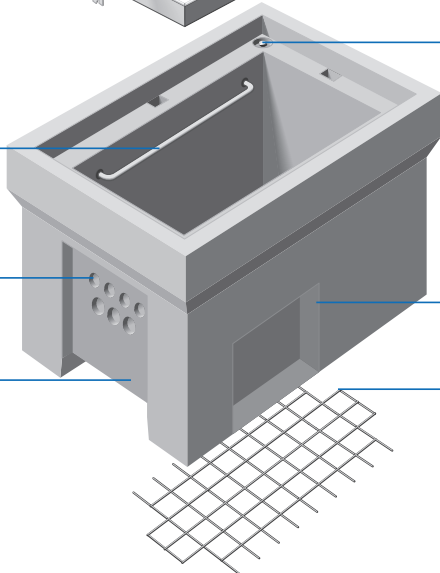

Manutention :  
ancres de levage

Équipement intérieur :  
2 supports équerres

Pré-trous

Ø 45 mm et Ø 60 mm  
selon usines de fabrication

Masque pré-cassable  
390 x 340 mm  
sur petits piédroits

Masque pré-cassable  
300 x 200 mm  
sur grands piédroits  
Armature pour radier  
à couler sur chantier

\*Cadres et tampons vendus séparément. Cadre scellé en option.

Type L

- L0T
- L0TR
- L1T
- L1TR
- L2T
- L2TR
- L3T
- L3TR
- 1/2 L4T
- 1/2 L4TR S**
- L4T
- L4TR
- L5T
- L5TR
- L6T
- L6TR

Type M

- M2T
- M2TR

Type P

- P1T
- P1TR
- P2T
- P2TR

MISE EN  
OEUVRE  
CCTP

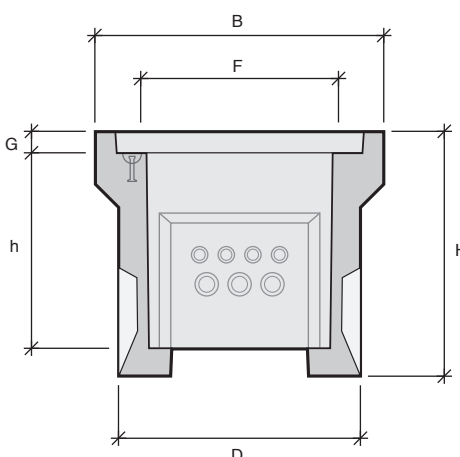
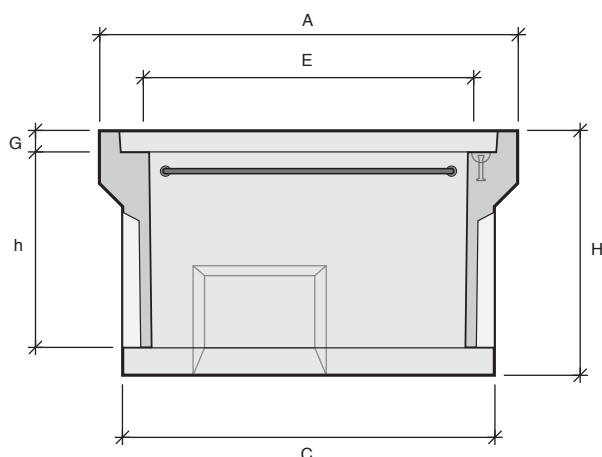

\* Profil 1



\* Profil 2

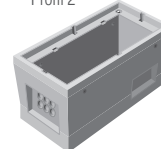

Désignation	Référence	Usines	Profils*	A Longueur (mm)	B Largeur (mm)	C Longueur radier (mm)	D Largeur radier (mm)	E Longueur intérieure (mm)	F Largeur intérieure (mm)	H Hauteur totale (mm)	h Hauteur utile (mm)	G Hauteur feuillure (mm)	Poids (kg)	Manutention
<b>1/2 L4TR</b>	<b>504115</b>	<b>EB</b>	1	1145	780	1037	672	885	520	680	536	54	390	2 ancres de 1,3T
	<b>1/2 L4TR</b>	<b>SN</b>	1	1145	780	1010	645	885	520	680	536	54	400	2 ancres de 1,3T