

# L5TR STRADEASY®

À radier à reconstituer



C 250



P 98-050-1



**Équipement intérieur :**

2 poteaux support de câbles  
3 anneaux de tirage  
3 échelons + 1 crosse descente

**Pré-trous**

Ø 45 mm et Ø 60 mm  
selon usines de fabrication

**Masque pré-cassable  
450 x 520 mm**

sur petits piédroits

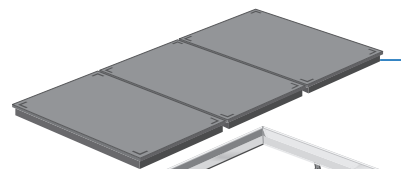

**3 tampons\***

990 x 633 mm

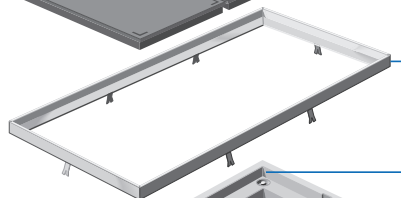

**Cadre\***

**Manutention :**

ancres de levage  
ou acicables

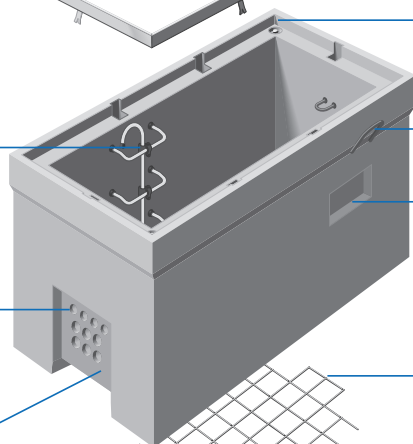

**Masque pré-cassable  
310 x 150 mm**

sur grands piédroits

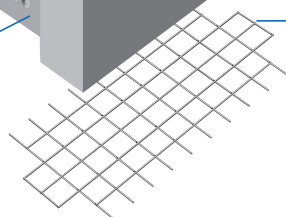

**Armature pour radier**

à couler sur chantier

\*Cadres et tampons vendus séparément. Cadre scellé en option.

Type L

- L0T
- L0TR
- L1T
- L1TR
- L2T
- L2TR
- L3T
- L3TR
- 1/2 L4T
- 1/2 L4TR
- L4T
- L4TR
- L5T
- L5TR S**
- L6T
- L6TR

Type M

- M2T
- M2TR

Type P

- P1T
- P1TR
- P2T
- P2TR

MISE EN  
OEUVRE  
CCTP

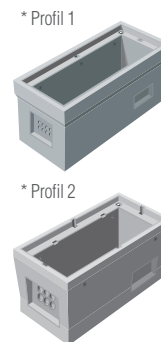
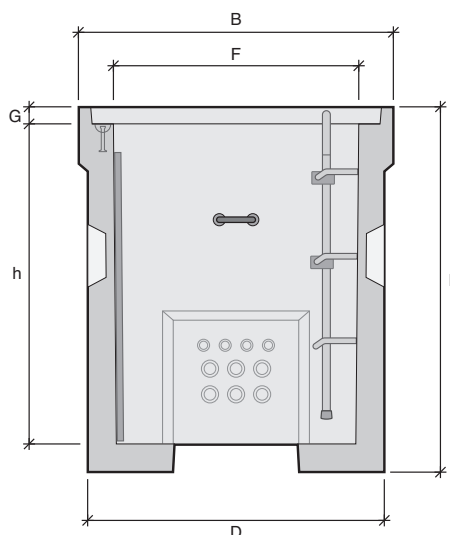
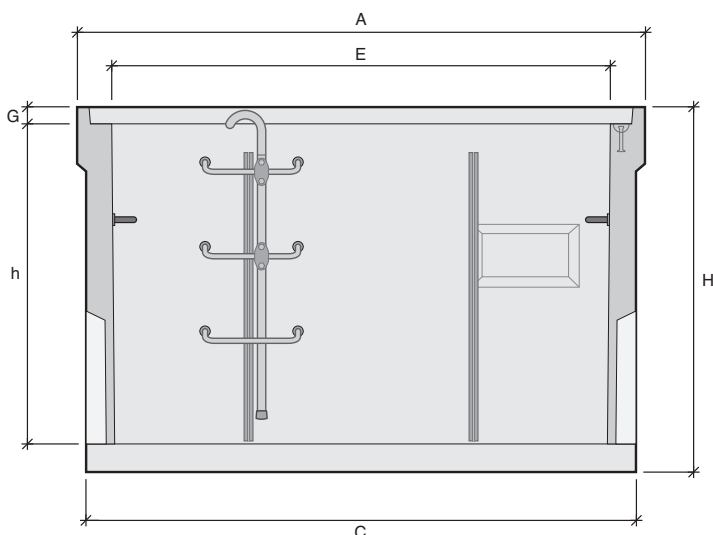

Désignation	Référence	Usines	Profils*	A Longueur (mm)	B Largeur (mm)	C Longueur radier (mm)	D Largeur radier (mm)	E Longueur intérieure (mm)	F Largeur intérieure (mm)	H Hauteur totale (mm)	h Hauteur utile (mm)	G Hauteur feuillure (mm)	Poids (kg)	Manutention
<b>L5TR</b>	110027	AA	1	2040	1130	1890	980	1790	880	1280	1130	70	1350	2 ancres de 2,5T
		BT	1	2040	1130	1930	1018	1790	880	1300	1132	63	1835	2 ancres de 2,5T
		EB	1	2045	1135	1895	983	1790	880	1355	1135	65	1600	4 ancres de 2,5T
		MX	2	2041	1132	1950	1040	1793	883	1300	1140	60	1664	2 ancres de 2,5T
		SN	1	2035	1125	1968	1058	1790	880	1300	1140	60	1830	2 acicables de 4T

AA : Aubergenville / BT : Beautiran / EB : Châteaufort-du-Rhône / MX : Maxilly / SN : Les Sorinières